

Y19 系列圆形电连接器

产品特点

- 规格有 4、7、11、19、37、55、85 芯；
- 采用麻花针结构，间距为 1.91mm，排距 1.65mm；
- 占用空间小，头、座采用螺纹盲插旋合对接，插拔柔和、锁紧可靠；
- 产品插头与插座可随意排列导向孔与导向柱，实现同型号防误插功能；
- 导线线芯截面积 $0.15\text{mm}^2 \sim 0.3\text{mm}^2$
- 执行标准：

Q/DJ-014-2019 《Y19 系列圆形电连接器详细规范》

技术特征

- 环境温度： $-55^{\circ}\text{C} \sim +125^{\circ}\text{C}$
- 震动：10Hz~2000Hz 196m/s^2
- 随机振动：功率谱密度 $0.6\text{G}^2/\text{Hz}$ 总加速度均方根值 28.4G
- 冲击： 1200m/s^2 6ms
- 额定电流：5A
- 接触电阻： $\leq 10\text{m}\Omega$
- 绝缘电阻： $\geq 5000\text{M}\Omega$ 500VDC
- 介质耐压：1500DV
- 机械寿命：500 次
- 耐盐雾：铝合金化学镀镍 48h 不锈钢钝化 96h

型谱排列

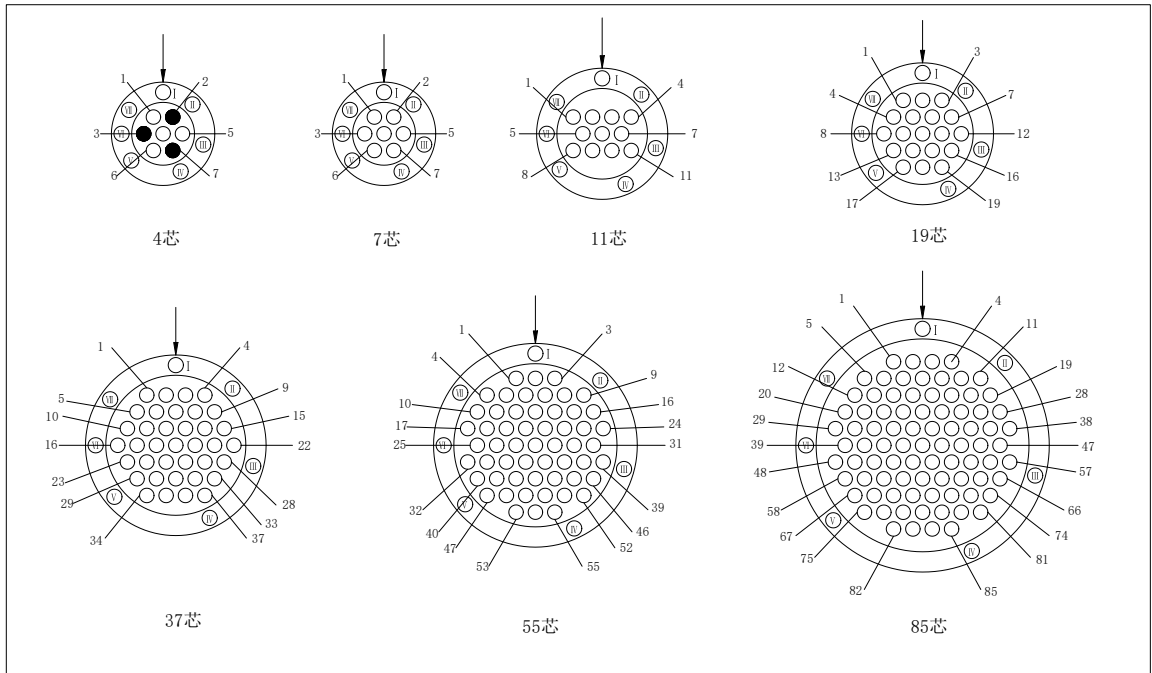

注：从插头对接端看（箭头所指位置表示主键位置）

订货标志

Y19/ 40 F □ P/S H N
① ② ③ ④ ⑤ ⑥ ⑦

- ① 主称代号：Y19
- ② 壳体类别：40-墙式方形法兰盘插座；
46-直式插头；
- ③ 表面处理：F-铝合金外壳、化学镀镍 S-不锈钢钝化
- ④ 接触件数目：4、7、11、19、37、55、85
AA、AB.....接触件改型
- ⑤ 接触件种类：P-插针、S-插孔
- ⑥ 接触件端接形式：H-压接式 S-焊接式
- ⑦ 主键/键位定位：N-标准（可不标注）A、B、C、D、E、F、G

主键/键位定位

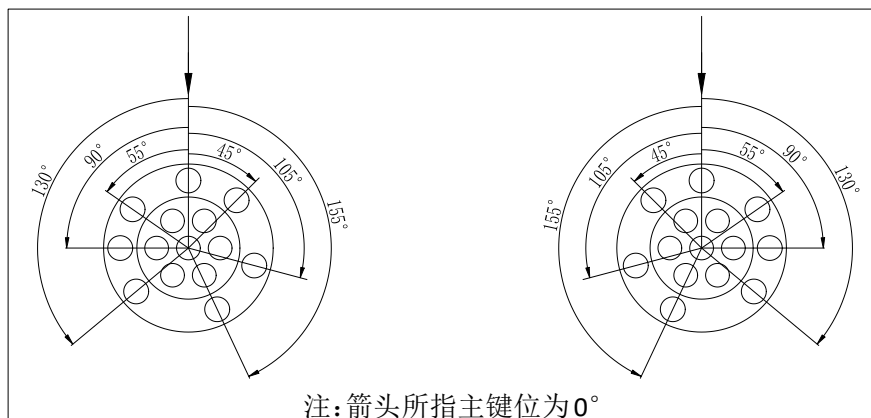

插头插合面视图

插座插合面视图

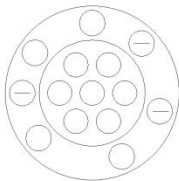
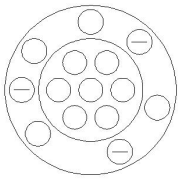
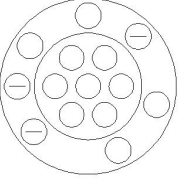
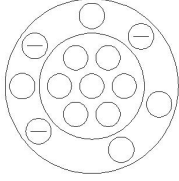
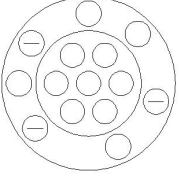
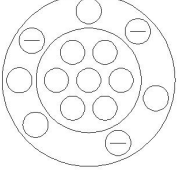
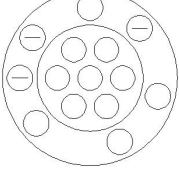
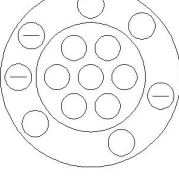
键位 排列	插头 (需留键位)							示意图
	0°	45°	105°	155°	230°	270°	305°	
N	○	-	-	○	○	-	○	
A	○	-	○	-	○	-	○	
B	○	-	○	○	-	-	○	
C	○	-	○	○	-	○	-	
D	○	○	-	○	-	○	-	
E	○	-	○	-	○	○	-	
F	○	-	○	○	○	-	-	
G	○	○	-	○	○	-	-	

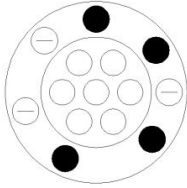
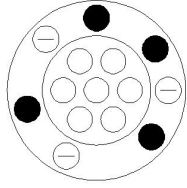
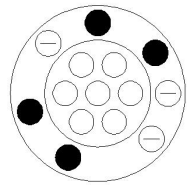
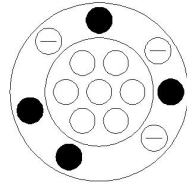
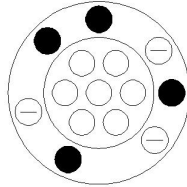
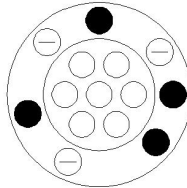
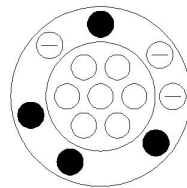
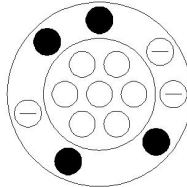
键位 排列	插座（需装键位）							示意图
	0°	45°	105°	155°	230°	270°	305°	
N	●	-	-	●	●	-	●	
A	●	-	●	-	●	-	●	
B	●	-	●	●	-	-	●	
C	●	-	●	●	-	●	-	
D	●	●	-	●	-	●	-	
E	●	-	●	-	●	●	-	
F	●	-	●	●	●	-	-	
G	●	●	-	●	●	-	-	

标志示例

Y19/46F19PH

以上标志表示铝合金外壳、化学镀镍，接触数目为 19，接触件尾端形式是压接式的 N 型键位直式插头。

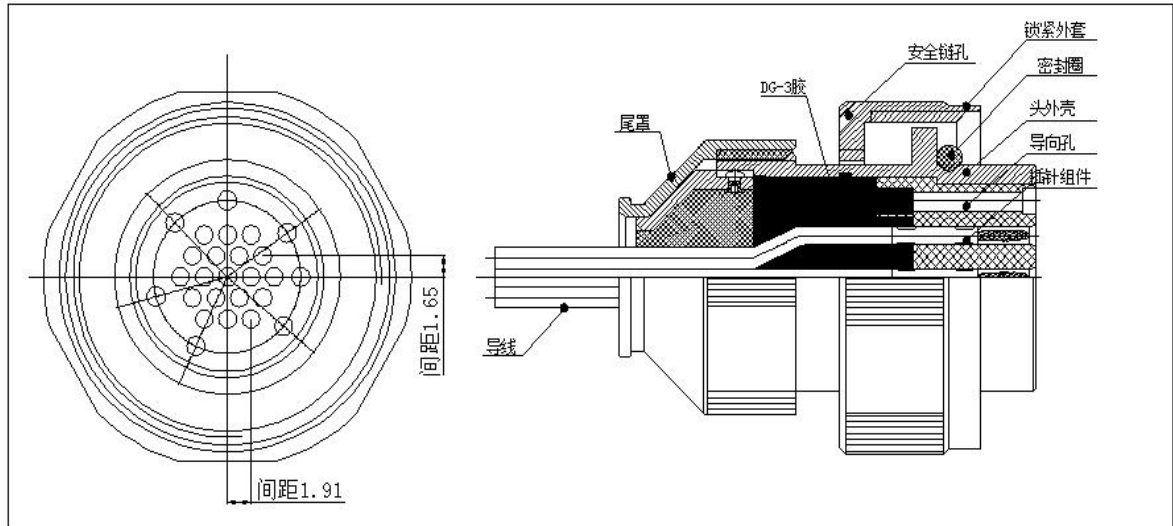

Y19/46F19PH

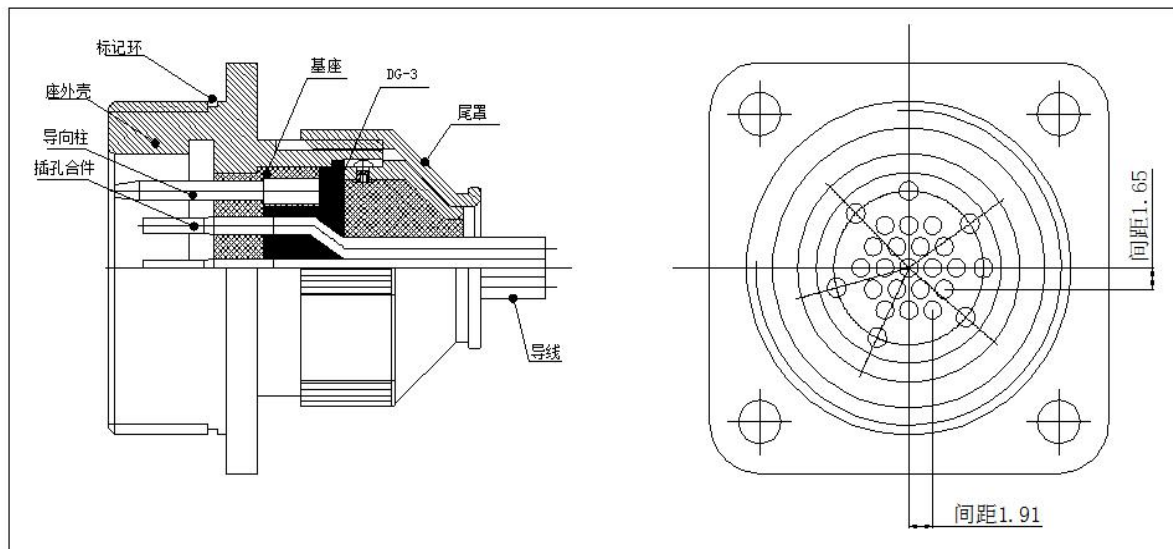

Y19/40F19SH

三维模型如图

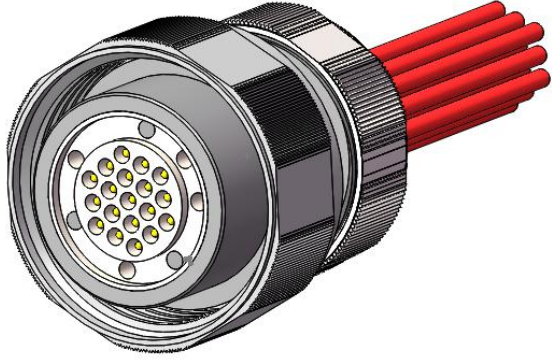

Y19/46F19PH

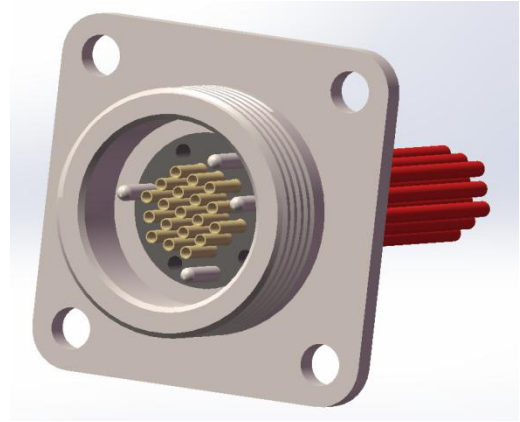

Y19/40F19SH

产品外形尺寸图

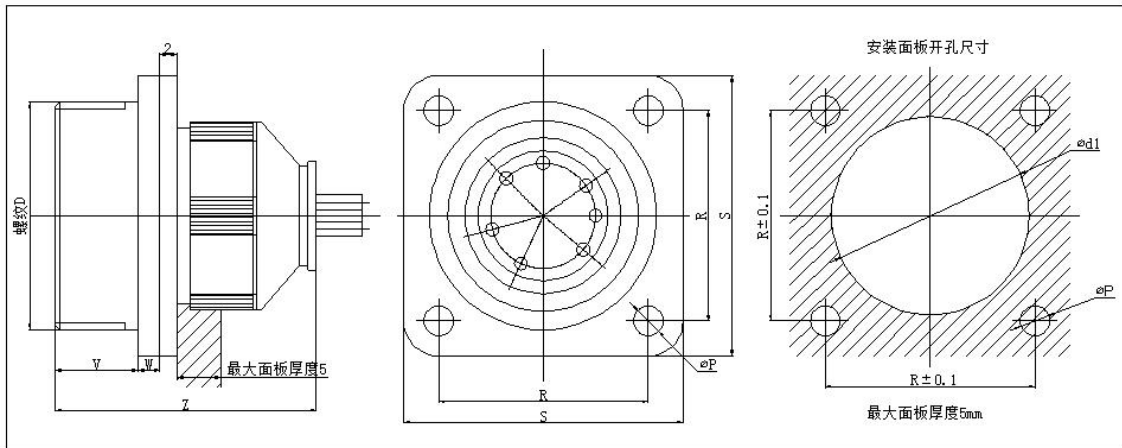

Y19/40F□SH

订货标志	R	S	P	螺纹 D	V	W	Z _{max}	d1(板前 min)
Y19/40F4SH	20.62	26.2	3.4	M22×1.5-6h	9.5	3	33	19.2
Y19/40F7SH	20.62	26.2	3.4	M22×1.5-6h	9.5	3	33	19.2
Y19/40F11SH	23.02	28.6	3.4	M24×1.5-6h	9.5	3	33	21.2
Y19/40F19SH	24.62	32.6	3.4	M26×1.5-6h	9.5	3	33	23.2
Y19/40F37SH	29.36	36.53	3.4	M30×1.5-6h	9.5	3	33	26.2
Y19/40F55SH	31.76	39.7	3.4	M32×1.5-6h	9.5	3	33	29.2
Y19/40F85SH	34.93	42.88	3.4	M36×1.5-6h	9.5	3	33	33.2

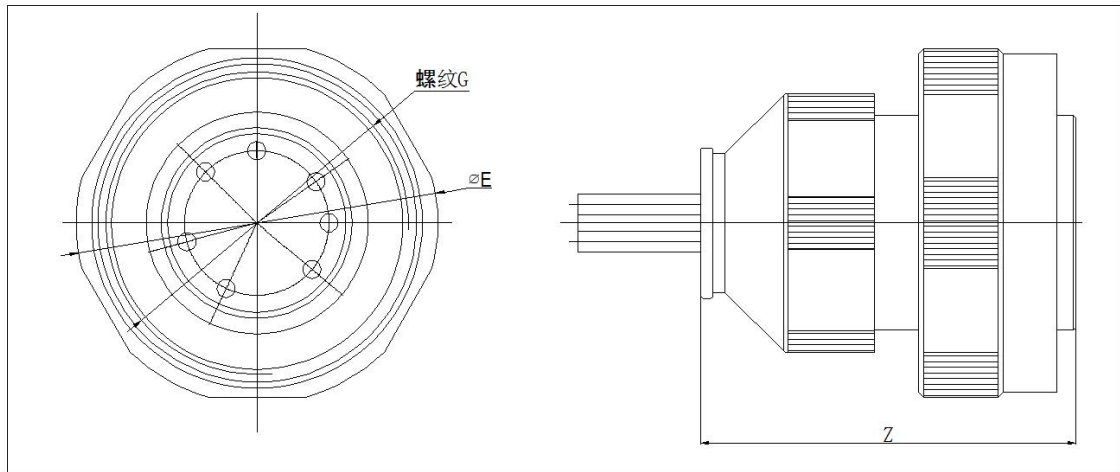

Y19/46F□PH

订货标志	E	螺纹 G	Zmax
Y19/46F4PH	26	M22×1.5-6H	34
Y19/46F7PH	26	M22×1.5-6H	34
Y19/46F11PH	28.6	M24×1.5-6H	34
Y19/46F19PH	31	M26×1.5-6H	34
Y19/46F37PH	34	M30×1.5-6H	34
Y19/46F55PH	36	M32×1.5-6H	34
Y19/46F85PH	40	M36×1.5-6H	34